



Marking and Application Guide

DOORS, WINDOWS AND RELATED HARDWARE

FIRE, SMOKE, EGRESS AND WINDSTORM RELATED APPLICATIONS

JULY 2016

PREFACE

Fire and smoke protection - Building codes rely on fire and smoke protection features to safeguard the public from fire and other hazards attributed to the built environment and to provide safety to fire fighters and emergency responders during emergency operations. One aspect of this protection is based on limiting the movement of fire, along with the associated smoke and toxic gases, through the building using a compartmentation approach. This includes requiring fire-resistance-rated fire walls, fire barriers, fire partitions, smoke barriers, shaft enclosures and horizontal assemblies to be provided to limit the spread of fire. It also includes requirements designed to limit the movement of smoke and toxic gases through the building using smoke barriers and partitions. This passive protection is an integral part of the overall safety scheme included in the codes.

An important aspect of limiting the spread of fire, smoke and toxic gases is protecting openings in fire and smoke rated assemblies that are provided to allow the building to be functional. Opening protective products are provided to protect these openings. These include fire doors and frames, fire windows and frames, and leakage rated door and window assemblies.

UL certifies a wide range of products that are covered by opening protective requirements in building codes. These products and materials, and the applications for which they are certified are covered in detail in this guide. Since some of the products are also certified for use as part of the building's means of egress system or for resistance from damage from wind-borne debris, information on these applications is also covered in this guide. Doors, windows, and related hardware that have been certified by UL to provide protection against burglary, robbery or theft are not covered in this guide. More information on those products is located in UL's Online Certifications Directory under security equipment.

Means of egress - Doors serving a means of egress system are required by building and life safety codes to meet specific requirements that help provide a continuous and unobstructed path of travel from any occupied portion of a building or structure to a public way. UL certifies doors and hardware that are specifically evaluated for use as part of the means of egress system.

Windstorm rated assemblies - Concern about potential damage to building exteriors caused by hurricanes and tornadoes has resulted in regulations being adopted to provide protection from wind-borne debris. UL certifies windstorm rated doors, hardware and other building assemblies for use in these applications.

UL has developed this guide for use by code authorities, architects, contractors, installers and other interested parties. It is intended to aid in understanding the basic components of fire door and fire window assemblies, in association with the applicable codes and standards to facilitate safe, code-compliant installations.

UL Marking and Application Guides are updated as necessary due to new product development, changes in the codes, or the need for clarification. To confirm the current status of any UL Marking and Application Guide, please consult the Code Authorities page of the UL Web site at www.ul.com/codeauthorities or www.ul.com/markingguides.

Codes and Advisory Services Department
UL LLC
333 Pfingsten Road
Northbrook, IL 60062
ulregulatoryservices@ul.com
800-595-9844

Contents

1. INTRODUCTION	4
A. USE OF THIS GUIDE	4
B. INFORMATION ON CERTIFICATION, LISTING AND CLASSIFICATION	4
C. UL MARK CONSIDERATIONS	5
D. FIELD EVALUATIONS	6
2. OPENING PROTECTIVES	7
A. FIRE-RESISTANCE-RATED GLAZING	7
B. FIRE-PROTECTION-RATED GLAZING	8
C. FIRE DOORS	8
D. FIRE DOOR AND WINDOW FRAMES	11
E. LEAKAGE RATED DOOR ASSEMBLIES	15
F. FIRE DOOR AND WINDOW HARDWARE AND ACCESSORIES	16
3. MEANS OF EGRESS RELATED DOOR CERTIFICATIONS	17
4. WINDSTORM RATED DOOR ASSEMBLIES	19
5. DOOR AND WINDOW SELECTION AND INSTALLATION	20
6. DIAGRAMS OF COMPLETE ASSEMBLIES	24
ROLLING STEEL FIRE DOOR ILLUSTRATION	24
SWINGING-TYPE FIRE DOOR ILLUSTRATION	25
DOUBLE FIRE DOOR ILLUSTRATION	26
APPENDIX A - CODES AND STANDARDS	27
NFPA 80	27
NFPA 105	28
Other Standards	28
APPENDIX B - DOOR, WINDOW AND RELATED HARDWARE CATEGORIES	29
Fire Doors	29
Fire Windows	29
Fire Door and Window Frames	29
Fire Door and Window Hardware	30
Fire Door Accessories	30
Fire Door Closers, Holders and Operators	30
Means of Egress Related Certifications	31
Windstorm Rated Assemblies	31
APPENDIX C: DOOR AND WINDOW CODES AND STANDARDS	32
INDEX	34

1. INTRODUCTION

A. USE OF THIS GUIDE

This guide is intended to assist code authorities, designers, and installers in determining the suitability of specific doors, windows and related hardware in a particular installation and use, and to address concerns related to fire, smoke, egress and windstorm related performance.

A four-letter code following each product category s in this guide is the UL product category code designation.

Each UL product category code provides a direct link to the Guide Information for the product category. The Guide Information includes the scope of the products covered, information relating to limitations or special conditions applying to the product, the requirements used for the investigation of the products, general installation and use information, and information on product markings and the UL Mark to be used on the product. Guide information is available in the UL Online Certifications Directory at www.ul.com/database or on UL Product Spec at www.ul.com/productspec.

The product markings identified in this Guide do not include every possible marking that could be provided either on a product or in its installation or operation instructions. The purpose of this Guide is to provide you with an indication of the type of text and location of markings that address features that may be critical in determining if a product is certified and / or if it is installed correctly. Refer to the specific Guide Information for the product category for additional marking information.

The numbering for code sections used in this document may change as the code is updated. A list of model codes and standards applicable for products covered by this guide can be found in Appendix B.

B. INFORMATION ON CERTIFICATION, LISTING AND CLASSIFICATION

Most codes and regulations require the certification of these products to applicable safety-related standards. They also may require these products to be certified to performance standards as well. Products that are certified to safety-related standards have been evaluated with regard to all reasonably foreseeable safety-related hazards, including fire, electrical shock and mechanical hazards. Such products are termed “UL Listed.” Products that are certified to a limited range of hazards, or for use under specific conditions are termed “UL Classified”. Alternatively, any of these products can be “UL Certified” and bear the UL Certification Mark.

It is important to distinguish the difference between “UL Listed” and “UL Classified” and the relation these terms have with the term “listed,” as used in various codes. The term “listed” in the codes generally indicates that the product is required to be evaluated in accordance with the appropriate standard(s) by an independent third party certification organization such as UL. The term “listed” in the codes should not be confused with the term “UL Listed,” as explained above. It is important to recognize that not all certification agencies make this distinction in their certification services.

C. UL MARK CONSIDERATIONS

There are several types of UL Marks that can be found on doors, windows and related hardware. General information on each of these Marks is provided below. Each has its own specific meaning and significance. The only way to determine if a product has been certified by UL is to look for the UL Mark on the product itself.

The UL Mark on a product means that UL has tested and evaluated representative samples of that product and determined that they meet the requirements in the applicable standard(s). Under a variety of UL programs, certified products are periodically checked by UL at the manufacturing facility to determine that they continue to comply with the standard(s).

The UL Marks may only be used on, or in connection with products certified by UL, and under the terms of a written agreement between the manufacturer and UL.

IDENTIFICATION OF UL CERTIFIED PRODUCTS

Launched in mid-2013, the enhanced UL Certified Mark can be used on both UL Listed and Classified products and is intended to make it easier and simpler for stakeholders to understand the scope of UL's certifications of a specific product. The enhanced UL Certified Mark makes it possible to bundle multiple UL certifications for multiple geographies into a single Mark design. Today, this mark is used for products certified to U.S., Canadian, European and Japanese requirements. This Mark utilizes a unique identifier to enable stakeholders to search UL's Online Certifications Directory at www.ul.com/database to quickly to review detailed certification information.

All currently existing versions of UL's Listing and Classification Marks remain valid and should continue to be accepted as an indication of certification.

UL expects the transition to the Enhanced Mark to happen over time, so you may not see it in the immediate future. For more information on this important development, please go to www.ul.com/markshub > Resources. Access to the Marks Hub is free and open to all regulators, but registration to use it is required.



UL Listing Mark

This is one of the most common UL Marks. If a product carries this Mark, it means UL found that representative samples of this product met UL's *safety* requirements. These requirements are primarily based on UL's own published Standards for Safety, or other recognized third party standards. The UL Listed Mark includes the UL symbol, the word "Listed," the product or category name, and a control number assigned by UL.



UL Classification Mark

This Mark appears on representative samples of products that UL has evaluated but only with respect to specific properties, a limited range of hazards, or suitability for use under limited or special conditions. The UL Classified Mark includes the UL symbol, the word "Classified," a statement of the scope of evaluation, the product or category name, and a control number assigned by UL.



D. FIELD EVALUATIONS

You may encounter situations in which you are unable to determine if a product has been listed by a third-party organization. Or in other situations you might encounter a product bearing a listing label that may have been modified in the field, and now you question whether or not the product still complies with the applicable standard. UL offers a field evaluation service that provides data to assist you in making your decision whether to accept the product and/or approve the installation. Anyone directly involved with a product – including manufacturers, owners, contractors, and regulatory authorities – can request a Field Evaluation. Detailed information for this program can be found on UL's Web site at www.ul.com/field.



2. OPENING PROTECTIVES

In order to provide for an acceptable level of life safety and property protection, model codes require the use of fire-resistance rated assemblies and smoke barriers and partitions to form compartments to keep fire and smoke from readily moving throughout the building. However, in order for the building to serve the needs of its occupants, openings in these fire and smoke rated assemblies are required to serve the traffic needs of the occupants and make the building accessible. Model codes require some of these openings to be protected with opening protectives. Although not a defined term, opening protectives include fire doors, fire windows, fire shutters, and smoke and draft control doors and windows.

During normal use of the building, opening protectives may be open, but during a fire condition they must automatically (without human aide) close and latch for the building to maintain the desired level of fire and smoke protection.

The type and ratings of the walls in which they are installed dictate the parameters that the opening protectives must meet. Section 716 of the IBC, for example, includes detailed requirements for opening protectives, including ratings and size limitations.

A. FIRE-RESISTANCE-RATED GLAZING

Fire-resistance rated glazing tested as part of a fire-resistance-rated wall assembly in accordance with the Standard for Fire Tests of Building Construction and Materials, [UL 263](#), is covered under the Fire-resistance Rated Glazing Materials ([CCET](#)) category. These materials are investigated for use in ([BXUV](#)) fire-resistance designs. The glazing materials have been investigated for use in specific fire-resistive floor-ceiling, wall and/ or partition constructions with respect to (1) construction details, and (2) maximum size of individual glazing panels, as described in the individual design illustrations ([BXUV](#)). This type of glazing material provides the insulation properties needed to achieve compliance with the UL 263 temperature rise requirement.

Assemblies incorporating fire-resistance-rated glazing comply with all of the requirements that a fire-resistance-rated wall must meet (e.g. fire, temperature and hose stream). Therefore, codes do not limit the quantity of fire-resistance-rated glazing that can be used in a wall. From a practical standpoint this glazing tends to be at least 2 inches thick in order to limit thermal transmission of heat from one side to the other. These materials have not been investigated by UL to determine compliance with safety glazing requirements.

UL certified fire-resistance-rated glazing materials include UL symbol with the word CLASSIFIED above the UL symbol and the manufacturer's name. The marking for fire-resistance-rated glazing materials intended for use in fire-resistance rated walls includes an identifier in the form:

W - xxx

Where "W" indicates the glazing meets the wall assembly criteria and "xxx" indicates the fire-resistance rating period in minutes

B. FIRE-PROTECTION-RATED GLAZING

Fire-protection-rated Glazing Materials ([KCMZ](#)) are intended for use in fire windows, fire doors and fire door frames with transoms and/or sidelights that are provided with suitable glazing frame members. These products are investigated in accordance with [UL 9](#), Standard for Fire Tests of Window Assemblies. These products are Classified for fire ratings of 3/4 hour, 1 hour, 1-1/2 hours, and 3 hours, or a fire rating of 1/3 hour (20 min) without hose stream as indicated in the individual Classifications.

Fire-protection-rated glazing materials are intended for installation in fire windows, fire doors, and fire door frames with transoms and/or sidelights that are provided with suitable glazing frame members. Unless otherwise indicated in the individual Classifications, these materials have not been investigated by UL to determine compliance with safety glazing requirements.

UL certified glazing materials include UL symbol with the word "CLASSIFIED" above the UL symbol and the manufacturer's name. The marking for glazing materials intended for use in fire doors includes:

UL 10B and/or UL 10C, and
D - H - T – xxx

Where:

"D" indicates the glazing is suitable for use in fire door assemblies

"H" indicates hose stream

"T" indicates a 450°F temperature rating

"xxx" indicates the fire-protection rating period in minutes

The marking for glazing materials intended for use in fire windows includes a reference to UL 9 and a marking in the form of "OH – xxx", where "OH" indicates compliance with the fire and hose stream requirements and "xxx" indicates the fire-protection rating period in minutes.

C. FIRE DOORS

UL certifies fire doors under a variety of different product categories that reflect the type or use of the door and the criteria used to evaluate them. See Appendix A for a complete list of fire door product categories, and the UL Standards used to certify doors under these categories.

Some fire doors are supplied as complete assemblies, including the frame, hardware and other accessories. In other cases, fire doors are supplied independently from the other components, and assembled at the job site with the fire door frame, glazing, hardware, and/or other accessories to form a fire door assembly, which provides the degree of fire protection required for the opening.

Fire-protection ratings – Fire doors include a rating of 4, 3, 1-1/2, 1, and ¾ hours, or 30 or 20 minutes, which indicates the duration of exposure to fire.

Temperature rise ratings - Some fire doors contain a temperature-rise rating on the Classification Mark. This rating is intended for use in determining compliance with the temperature-rise requirements contained in the International Building Code, NFPA 101, and NFPA 5000. A temperature-rise rating of 250°F, 450°F or 650°F reflects the limiting potential temperature rise on the unexposed surface of the door during the first 30 minutes of fire exposure. Classification Marks that do not indicate a temperature rise are for doors which either develop a temperature rise in

excess of 650°F on the unexposed surface of the door or have not been evaluated for temperature rise rating.



Glass lights in fire doors in excess of 100 sq. in. shall be fire-resistance-rated and shall also be evaluated as a component of the door assembly in accordance with UL 10B and/or UL 10C. Doors with glass light panels meeting the size limitations and the rating requirements of the installation code carry the same rating as similar doors without glass light panels.

Glazing materials - Glazing materials covered under the fire door categories are Classified for a fire-protection rating only. The glazing materials are to be installed in the fire doors in accordance with NFPA 80 and the installation instructions provided by the manufacturer of the door, glass light frame or glazing material. See Fire Door Glass Light Frames ([GVVX](#)) and Fire-protection-rated Glazing Materials ([KCMZ](#)).

A door prepared at the factory for a glass light includes the glazing members (frame) but normally does not include the glazing itself. Glazing materials are usually provided by other than the door manufacturer and installed at the time of the door installation.

Oversized doors - Freight elevator type, rolling steel type, and sliding or swinging steel-covered composite type, hollow-metal type, metal-clad (Kalamein) type, sheet-metal type and tin-clad type are fire tested up to the sizes recorded in the tabulations under their respective product categories. Doors exceeding this size limitation are supplied with a Classification Mark for Oversized Fire Door which indicates compliance (except for size), with all requirements for design, materials and construction of the maximum size door fire tested.

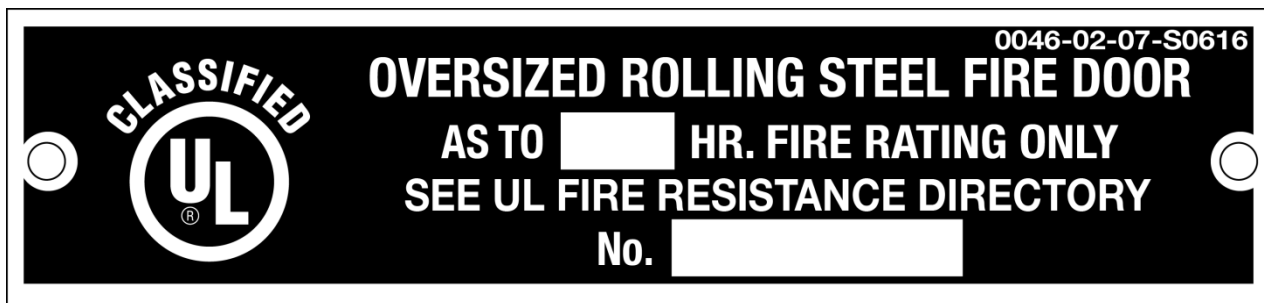

Similarly, a Certification Mark for Passenger Elevator Fire Door Frame Assemblies incorporating a transom panel can be provided when such frame/transom panel assemblies, designed for use with specific Classified Passenger Elevator Fire Doors and Listed Passenger Elevator Fire Door Hardware, exceed the maximum heights which have been subjected to Standard Fire Tests. As with the oversize doors described above, prospective users should first ascertain from the code authority whether the oversize frame assembly is acceptable for any given location.

Positive pressure fire doors – Some code applications require swinging fire door assemblies to comply with the Standard for Positive Pressure Fire Tests of Door Assemblies, [UL 10C](#). To assist in selecting components of fire door assemblies tested under positive pressure, eight categories, identified as A through J, were established.

Category A Doors — A fire door that does not require the addition of other components such as edge seals to comply with positive-pressure requirements. It also includes doors that have been prepared with edge seals in the manufacturing process. See Swinging-type Fire Doors, Positive-pressure Tested ([GSZN](#)) for the individual certifications.

Category B Doors — A fire door that requires the addition of an edge seal to comply with the positive-pressure requirements. The edge seals are added to the door edge or to the frame. See Swinging-type Fire Doors, Positive-pressure Tested ([GSZN](#)) for the individual door certifications. See Gasketing and Edge-sealing Materials for Fire Doors, Positive-pressure Tested ([GVYI](#)) for the Category G Edge Sealing Systems individual certifications.

Category C Frames — A fire door frame that plays an integral part in the door assembly in complying with the positive-pressure requirements. Three-sided hollow metal frames are generally not required to be positive-pressure tested. See Fire Door and Window Frames ([GVTV](#)) for a listing of those manufacturers that can provide steel frames.

Category D Door/Frame Assemblies — A door and frame assembly that is labeled as assembly. Category D door and frame assemblies are Listed under Special-purpose Fire Doors ([GSXZ](#)).

Category F Light Kits — Light kits that have been investigated for positive pressure. See Fire Door Glass Light Frames ([GVVX](#)) for the Listings of the positive-pressure glass light frames investigated to positive pressure.

Category G Edge Sealing Systems — Edge seals that are surface applied to frames or doors. These seals may or may not have an effect on meeting the leakage requirements for the smoke ("S") rating. See Gasketing and Edge-sealing Materials for Fire Doors, Positive-pressure Tested ([GVYI](#)) for the Category G Edge Sealing Systems individual certifications.

Category H Smoke and Draft Control Gasketing — Gasketing materials that are added to a door assembly to comply with the requirements of UL 1784. See Gasketing and Edge-sealing Materials for Fire Doors, Positive-pressure Tested ([GVYI](#)) for the Category H Smoke and Draft Control Gasketing for the individual certifications.

Category J Gaskets — Gasketing materials that are added to a door assembly for purposes other than Category G Edge Seals and Category H Smoke and Draft Control Gaskets. They are used for purposes such as weather stripping and for sound control. They meet the requirements for positive-pressure tests and can be used on these assemblies. These gasket materials do not contribute to the door meeting the positive-pressure fire test. They are only investigated so that they do not contribute to flaming when tested to the positive-pressure-test requirements.

Fire door markings – UL certified fire doors include the UL symbol, the word CLASSIFIED and the following information:

- Fire door category name (see Appendix A)
- Hourly rating (e.g. 4 HR, 3 HR, 1-1/2 HR, 1 HR, 3/4 HR, 30 MIN or 20 MIN)

- Temperature rise, if established – (e.g. 30 MIN - 250°F MAX, 30 MIN - 450°F MAX, 30 MIN - 650°F MAX)

Additional information may also be required to be marked on the fire doors as described under the individual fire door categories included in Appendix A.



Installation instructions – Fire doors are intended to be installed in accordance with the installation instructions provided by the manufacturer.

D. FIRE DOOR AND WINDOW FRAMES

UL fire door and window frames are certified under the Fire Door and Window Frames ([GVTV](#)) category. This category covers fire door frames, fire window frames, and 20-minute-type door frames or window frames fire tested without hose stream. These frames are intended for installation in conjunction with fire doors, hardware, glazing and/or other accessories that together form a fire door assembly or fire window assembly, which provides the degree of fire protection to the opening.

Listing Mark considerations – UL certified fire door frames and window frames bear a UL Listing Mark that appears on the frame where visible after installation. Fire doors, in comparison, include a UL Classification Mark, as described above.

Fire door frame and fire window frame Listing Marks include the UL symbol, the word LISTED and a description of the certified product. This could include descriptions such as "Fire Door Frame", "Transom or Sidelight Panel", "Fire Window Frame (3/4 Hr or 1 Hr) Fire Rating", "Sheet-Metal Mullion for Nonbearing Fire Window Frames" and similar wording. The Listing Mark typically describes if the frame includes sidelights and/or transom panels, may include hourly ratings, and may describe if the frame was evaluated without hose stream.

When the Listing Mark of UL is stamped into the frame, one of the following abbreviated product identities may be used:

"FDF" in lieu of "Fire Door Frame"

"FDF-L" in lieu of "Fire Door Frame for Lights"

"FDF-P" in lieu of "Fire Door Frame with Panels"

"FDF-20" in lieu of "Fire Door Frame Fire Rating 20 Minutes"

"FDF-20 NH" in lieu of "20 Minute Type Door Frame Fire Tested Without Hose Stream"

Installation instructions - Fire door and fire window frames are intended to be installed in accordance with NFPA 80 and SDI A250.11. Installation instructions are not required to be shipped with frames that are to be installed in accordance with NFPA 80 and SDI A250.11. Installation details other than those specified in NFPA 80 and SDI A250.11 are shipped with the frames. Elevator door frames, wood frames and other special use frames as identified in the individual certifications are intended for installation only in walls of the types shown in the installation instructions accompanying the door or window frame.

Hourly ratings - Door frames are intended for use in applications where codes require a minimum hourly rating for the overall door or window assembly. However frames may or may not be marked with hourly ratings. When combining doors, frames and hardware with different ratings the overall rating of the assembly will be the lesser of the ratings of any of the individual components.

Door frames bearing a UL Certification Mark without an hourly rating and provided with masonry wall anchors can be used in conjunction with fire doors rated up to 3 hours and installed in masonry walls having fire resistance ratings not less than the rating of the door.

Door frames bearing a UL Certification Mark without an hourly rating and provided with steel stud or wood stud anchors can be used in conjunction with fire doors rated up to 1-1/2 hours and installed in steel stud and wood stud walls steel stud cavity walls, steel stud shaft walls and wood stud cavity walls protected with gypsum board, having fire resistance ratings not less than the rating of the door nor more than 2 hours.

Elevator and special use frames - Elevator door frames, frames of the slip-on type, wood frames and other special use frames as identified in the individual certifications are for installation only in the walls of the types shown in the installation instructions accompanying the door frame.

Elevator door frames are intended for use with sliding freight or passenger elevator fire door designs for use in dry wall or masonry shaft construction, as identified in the individual certifications for door frames.



Special frames are constructed of materials other than steel and are intended for use with doors rated less than 3 hours. The hourly ratings for special frames are shown in the individual certifications.

Some special frames are intended for use with Classified fire doors and Listed transom panels of a specific design. These frames and the labeled components are identified in the individual certifications.

Mullions, transom panels and other features - Standard door frames are of the single-unit or three-section type and consist essentially of steel head and jamb members, including hardware reinforcements, wall anchors, door stops, and provisions for anchoring to the floor.

Door frames may be provided with mullions, transom panels, or transom lights. In addition to the steel head and jamb members, these frames should be equipped with a steel mullion, transom bar, steel-covered composite transom panel, and glazing beads. Transom panel frames of standard construction are for use with doors rated up to and including 1-1/2 hours. Transom light frames glazed with labeled glazing material are intended for use with doors rated a max of 3/4 hour.

Some manufacturers can provide labeled transom panel frames for use with doors rated up to and including 3 hours as indicated in the individual certifications. Some manufacturers can provide labeled transom frames with hollow-metal transom panels with or without a transom bar. Transoms of solid construction are for use with doors rated up to and including 1-1/2 hours (unless otherwise noted for 3 hours in the individual certifications). Some manufacturers can provide labeled door frames with side panels or sidelights. Frames with side panels are for use with doors rated up to and including 1-1/2 hours. Frames with sidelights glazed with labeled glazing material are intended for use with doors rated a max of 3/4 hour.

Double egress frames are intended for use with double egress door designs as identified in the individual certifications.

Oversized frames - Freight elevator, passenger elevator and swing-type fire door frames incorporating transom panels exceeding the heights eligible for certification and which have not been subjected to standard fire tests that are otherwise found to be in compliance (except for size) with all requirements for design, materials and construction can be provided with an Oversized Frame Listing Mark. These oversized frame assemblies are intended for use with specific Classified freight elevator fire doors, passenger elevator fire doors, or swinging fire doors. Code authorities should be consulted as to whether the assembly is acceptable for a specific location. The Certificate can be a separate certificate or a label certificate affixed to the assembly.

20-minute rated frames - 20-minute type door frames may be provided with sidelights and/or transom lights as indicated in the individual certifications.

Standard 20-minute type door frames are of the single-unit pressed steel type and consist essentially of steel head and jamb members, including hardware reinforcements, wall anchors, door stops and provisions for anchoring to the floor.

A 20-minute type door frame with a transom and/or sidelight prepared at the factory for the glazing material does not normally include the glazing material itself. These frames should be glazed with Classified fire-protection-rated glazing materials ([KCMZ](#)).

20-minute type door frames fire tested without hose stream are intended for use with 20-minute rated door assemblies fire tested without hose stream. These frames are only intended for use in the applications specifically identified in the model codes, such as in door assemblies used in some corridor and smoke barrier applications.

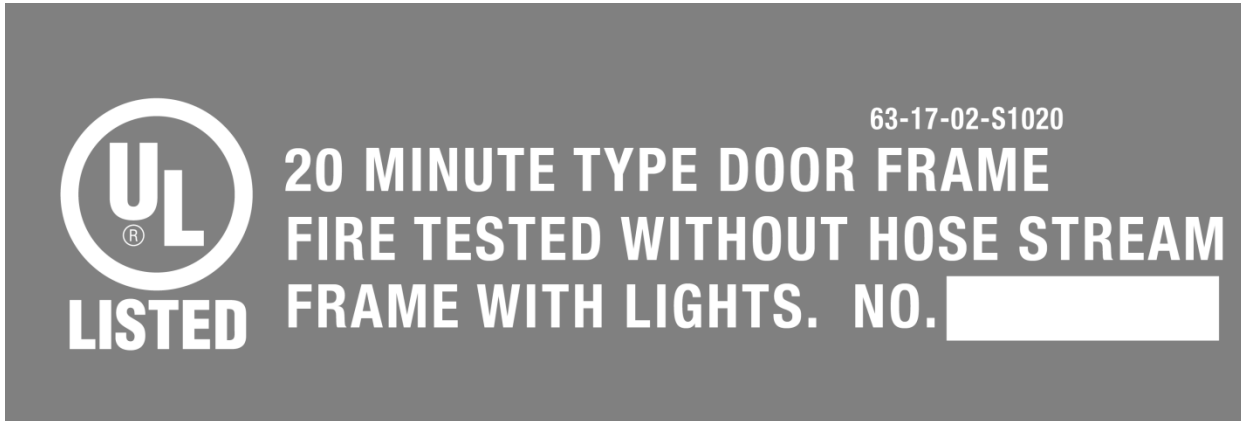

Positive pressure frames - All three-sided hollow-metal frames, manufactured from No. 18 gauge or heavier steel and properly anchored, will comply with the positive pressure test requirements. UL does not require that these frames to be marked for compliance with positive pressure. Every steel frame manufacturer under the Fire Door and Window Frames ([GVTV](#)) category is eligible to produce hollow-metal frames for compliance to positive pressure. Some manufacturers have opted to mark their frames for conformity to positive pressure as noted below.

Three-sided steel frames that comply with the UL 10C positive pressure test requirements bear a label that references UL 10C.

Window frames - Fire window frames consist of sash and mullions of various designs. Fire window frames are Listed for a 3/4 hour or 1 hour fire rating. In addition, some window frames are Listed for 20-minutes without hose stream as indicated in the individual certifications. The exposed area of individual glazing lights is limited to 1296 sq. in. with no dimension to exceed 54 in. unless otherwise stated in the individual certification. Fire window frames are intended to be installed in masonry-type walls unless otherwise identified in the individual certification.

Fire window frames intended to be installed in drywall construction, and supported directly by a noncombustible floor bear the supplemental marking "Fire Window Frame for Installation on Noncombustible Floor with Base Anchor Provided on Frame."

Fire window frames intended to be installed above the floor in drywall construction should be installed as specified by the installation instructions provided with the window frame.

20-minute type window frames fire tested without hose stream are typically pressed steel window frames of the hollow-metal type. Standard 20-minute type window frames consist of formed steel sheet, reinforced as required, with a stationary-type single sash or with stationary type multiple sashes.

The window frame prepared at the factory for the glazing material does not normally include the glazing material. Classified glazing material is usually provided by other than the window frame manufacturer and installed after installation of the window frame in the building.

Oversized frames - Fire window frames exceeding the height and width eligible for certification and which have not been subjected to standard fire tests that are otherwise found to be in compliance (except for size) with all requirements for design, materials and construction can be provided with an Oversized Frame Assemblies Listing Mark . Code authorities should be consulted as to whether the assembly is acceptable for a specific location.

E. LEAKAGE RATED DOOR ASSEMBLIES

Model codes often require doors installed in smoke partitions to meet the requirements for a smoke and draft control door assembly when tested in accordance with the Standard for Air Leakage Tests of Door Assemblies, [UL 1784](#). The air leakage rate of the door assembly is often specified, and typically cannot exceed 3.0 cubic feet per minute per square foot of door opening at 0.10 inch of water column for both the ambient temperature test and the elevated temperature exposure test.

UL certifies products for use in these applications under the Leakage-rated Door Assemblies ([OPBW](#)) category. These assemblies consist of combinations of individual component products, which include the door, frame, hardware, gasketing and other door accessories.

“S” rated door assemblies - Model codes often require doors installed in corridors and smoke barriers to meet the requirements for a smoke and draft control door assembly when tested in accordance with UL 1784. The air leakage rate of the door assembly is often specified, and typically cannot exceed 3.0 cubic feet per minute per square foot of door opening at 0.10 inch of water for both the ambient temperature test and the elevated temperature (400F) exposure test. Swinging fire doors, fire tested under positive pressure in accordance with UL 10C and bearing the Smoke and Draft Control Door "S" marking have been investigated in accordance with [UL 1784](#) and determined to have an air leakage rate of the door assembly not exceeding 3.0 cfm per square foot of door opening at 0.10 inch of water for both the ambient and elevated temperature conditions. These doors are intended to be installed in a Listed fire door frame marked with the letter "S," and provided with a UL Classified Category H gasketing material for fire doors.

Leakage-rated door assemblies are intended for installation in accordance with NFPA 105 and the installation instructions provided with each leakage-rated component. Leakage-rated door assemblies may be assembled at the job site, or may be factory assembled. Information concerning the specific air-leakage rating, mounting locations, installation clearances, and the like is provided in the detailed installation instructions accompanying each leakage-labeled product. The manufacturer's certification information in the UL Online Certifications Directory also describes the components used in the assembly.

Leakage ratings for door assemblies are determined at ambient air temperature (75°F) and/or elevated air temperature 400°F and at three air pressure differentials including 0.10, 0.20, and 0.30 in. water column.

Artificial bottom seals – UL 1784 allows an artificial seal to be applied to the bottom 6 inches of the test sample in order to obtain information on the extent of air leakage through the perimeter of a test sample without the sample leakage being influenced by the clearance at the bottom of the door. The artificial seal may be any material, such as an impermeable plastic sheet or tape. The manufacturer chooses whether an artificial bottom seal is used or not during the test.

NFPA 105 does not allow smoke door assemblies intended to be installed where pressurization is provided to control smoke movement to have an artificial bottom seal installed during the test.

Alternately, the International Building Code requires enclosed elevator lobby doors to comply with smoke and draft control door assembly requirements when tested in accordance with UL 1784 without an artificial bottom seal.

Leakage rated door assemblies are not marked to indicate if they were tested with or without an artificial bottom seal. This information, if needed, should be available in the manufacturer's installation instructions.

F. FIRE DOOR AND WINDOW HARDWARE AND ACCESSORIES

Fire door and window hardware and accessories are certified under a variety of product categories as described in Appendix A. Hardware includes locks, latches, hinges, electric strikes, flush and surface bolts, viewers and fire exit hardware. Accessories include fire door coordinators, cladding materials, glass light frames, and gasketing and edge seal materials. Fire door closers, holders and operators are also certified by UL.

Hardware and accessories may be installed at the manufacturer's facility, or may be assembled at the job site. In all cases installation is to be done in accordance with NFPA 80, NFPA 105 and the manufacturer's installation instructions.

Fire exit hardware – These devices are intended for use on swinging fire doors, which are intended to facilitate the safe egress of persons in the case of emergency, as well as provide fire protection for door assemblies. See the Means of Egress Related Door Certifications section for additional information.

Gasketing and edge seal materials – There is often confusion about whether UL certified gasketing and edge seal materials are required for fire doors used in smoke barriers and smoke partitions. There are two product categories covering these materials. The Gasketing Materials for Fire Doors ([GVWZ](#)) category includes gasket materials investigated in accordance with the Standard for Fire Tests of Door Assemblies, [UL 10B](#). The gasketing material is intended to be installed in accordance with the installation instructions packaged with the material. These materials have been investigated only with respect to determination that the materials do not adversely affect the fire rating of fire doors in which they are installed. Gasketing material identified for use at the meeting edges of pairs of doors is not intended to replace the astragal (if required by the door manufacturer) or to alter the clearance between doors, as specified in NFPA 80 or in the door manufacturer's installation instructions.

The Positive-pressure Tested Gasketing and Edge-sealing Materials for Fire Doors ([GVYI](#)) category includes materials investigated in accordance with UL 10C. Gaskets and edge seals are categorized as follows. These categories were previously discussed on in the Positive Pressure Fire Doors section.

Category G Edge Sealing Systems - Edge seals are gasket materials that have demonstrated their ability to assist the door in meeting the positive pressure fire test requirements. They expand and fill the gaps around the door edges to prevent the passage of hot smoke and gases. These materials are required for Category B Swinging Type Fire Doors, Positive Pressure Tested ([GSZN](#)). Edge seals are surface applied to frames or doors. These seals may or may not affect the leakage (smoke) requirements for the smoke ("S") rating. Edge Sealing Systems are either Classified for general use on all products in a door type family or limited to individual door manufacturers as noted in the individual Classifications. Edge seals that are also smoke seals are denoted as Category G/Category H Edge Seal/Smoke and Draft Control Gasketing in the individual Classifications.

Category H Smoke and Draft Control Gasketing - Gasketing materials that are surface applied to a door assembly to comply with the requirements of UL 1784. Smoke and draft control gasketing is either Classified for general use on all products in a door type family or limited to individual door manufacturers as noted in the individual Classifications.

Category J Gaskets - Gasket materials that are added to a door assembly for purposes other than Category G Edge Seals and Category H Smoke and Draft Control Gaskets. They are used for purposes such as weather stripping, sound control, etc. Category J Gasketing Materials have only been investigated to positive pressure with respect that they do not contribute to flaming during the fire test. They have not been evaluated for any contribution for a door assembly to help meet the positive pressure requirements.

3. MEANS OF EGRESS RELATED DOOR CERTIFICATIONS

Code requirements - A key life safety concept in building and life safety codes is providing a means of egress system that allows occupants to safely evacuate a building during an emergency. The means of egress is intended to provide a continuous and unobstructed path of travel from any occupied portion of a building or structure to a public way.

Codes include requirements for doors which serve the means of egress system, which are referred to as exit (egress) doors. Code requirements for exit doors include specific criteria that are not applicable for doors that are not in the means of egress travel path. These include the following:

1. Exit doors must be readily distinguishable from the adjacent construction and finish so they are easily recognizable as doors. Mirrors cannot be used on these doors, and they are not allowed to be concealed by curtains or other materials.
2. Codes specify the minimum width of door openings, which varies depending on the occupancy or area which they serve, and the maximum length of projections into the clear width.
3. Exit (egress) doors, with some exceptions are required to be of the pivoted or side-hinged swinging type. They are also required to swing in the direction of egress travel where they serve a room or area containing 50 or more persons or certain occupancy types.
4. Codes include specific requirements for exit door hardware which includes the hardware mounting height, locks and latches, special locking arrangements, and delayed egress locks, and other locking arrangements.
5. To minimize this risk of creating potential crowd crush problems at exit doors through which large numbers of people must pass, panic hardware is required in certain situations. For example exit doors serving a hazardous occupancy and exit doors serving spaces with an occupant load of 50 in certain occupancy types are not allowed to be provided with a latch or lock, unless it is panic hardware or fire exit hardware. Panic hardware is required to be listed in accordance with the Standard for Panic Hardware, [UL 305](#), and fire exit hardware must be listed in accordance with [UL 10C](#) and UL 305. Additional information on panic hardware and [UL 305](#) is included below.

UL certifications - UL certifies the following products for use with doors serving a building's means of egress system. Product category codes are indicated below.

Controlled Exit Panic Devices ([FULA](#)). This category covers devices intended for mounting on outward swinging exit doors to facilitate the egress of persons. When the system is activated, it is intended to monitor against unauthorized egress and allow exiting within 15 seconds, or 30 seconds when accepted by the code authority). These devices are intended to allow immediate exit in case of power failure or upon activation of an automatic fire alarm system.

The Listing Mark for these products includes the UL symbol the word LISTED and Controlled Exit Panic Device.

Exit Doors ([FUXV](#)) - This category covers sliding, swinging and bifold doors incorporating a panel that can be manually opened to permit exit travel. The assembly consists of a frame, doors and necessary hardware. Exit doors are intended for use in applications where codes allow power operated sliding or swinging doors, such as those installed in supermarkets.

In normal use these doors open upon the approach of a person or are provided with power-assisted manual operation. In the event of power failure, the door leaves open manually to allow egress travel or close when necessary to safeguard the means of egress.

These doors are tested to verify that the release mechanism is constructed so that a horizontal force of 50 pounds or less will open the emergency panel. Exit doors are investigated in accordance with the [UL Subject 1336](#) Outline of Investigation for Exit Doors. Exit doors certified by UL bear a Listing Mark that includes the UL symbol, the word LISTED, and Sliding Exit Door, Swinging Exit Door, Bifold Exit Door or Exit Door.

Exit Locks ([FUQV](#)) - This category covers assemblies intended for mounting on outward swinging doors for the purpose of locking such exit doors against unauthorized egress. These products have not been investigated for a fire resistance classification. Devices so Classified are covered under Hardware ([GWGR](#)). Exit locks are investigated in accordance with the [UL 305](#) standard for Panic Hardware. UL certified exit locks bear a Listing Mark that includes the UL symbol, LISTED, and Exit Lock.

Panic Hardware ([FVSR](#)) - This category covers devices intended for mounting on or integral with outward-swinging doors to facilitate the safe egress of persons in case of emergency. Panic hardware is investigated in accordance with [UL 305](#).

UL 305 requirements cover releasing devices actuated by an actuating bar (also referred to as a crossbar or push pad) or actuating paddle for outward-opening doors, designed to facilitate the egress of persons from buildings in the event of panic or other emergency. Among other criteria [UL 305](#) requires the actuating bar to extend across not less than one half of the width of the door leaf. The actuating paddle is an arm, push plate or paddle which functions as the activating mechanism of an exit lock on the egress side of the door. The active surface of the actuating paddle must be visually and physically distinct from the rest of the device.

UL certified panic hardware bears a Listing Mark that includes the UL symbol, LISTED, and Panic Hardware. Panic hardware that is additionally investigated to the BHMA A156.3 Exit Devices standard is so indicated in the individual Listings.

Special Locking Arrangements ([FWAX](#)) - This category covers assemblies intended to be mounted on door frames of outward-swinging exit doors for the purpose of locking such doors against unauthorized egress. These devices are designed to release automatically in case of a power failure or upon activation of an automatic fire-alarm system.

These devices are intended for use in applications where codes regulate special locking arrangements, delayed egress unlocking, access controlled egress, and electromagnetically locked exit (egress) doors. Refer to individual manufacturer's certifications to determine the applications for which their products are Listed.

The basic standard used to investigate special locking arrangements is the [UL 294](#) Standard for Access Control System Units. UL certified special locking arrangements bears a Listing Mark that includes the UL symbol, LISTED, SECURITY, and Special Locking Arrangement.

4. WINDSTORM RATED DOOR ASSEMBLIES

Concern about potential damage to building exteriors caused by hurricanes and tornadoes has spurred some states, including Florida and Texas, to adopt regulations to increase protection from windborne debris above and beyond the requirements included in model building codes. Buildings constructed in specific regions of these states are required to comply with these criteria.

These additional regulations typically require exterior building products ([ZHBA](#)) to comply with specific test protocols or standards and to be manufactured under a quality assurance program. UL certified windstorm rated building assemblies clearly identify the test criteria used during an investigation, and components and products used within these assemblies are subject to an ongoing factory (quality control) audit inspection as part of UL's Follow-Up Service program.

Windstorm Rated Swinging Door Assemblies ([ZHCH](#)) - This category covers exterior swinging door assemblies consisting of products and materials that have been investigated to specific test standards and protocols for specific ratings. Components within the assembly may include swinging doors ([ZHCW](#)), door frames ([ZHDL](#)), latching hardware ([ZHEM](#)), hinges ([ZHDX](#)) and other items, along with a description of the allowable wall constructions and, where applicable, the maximum impact energy resistance and maximum design pressure. Drawings are included as part of a rated assembly, along with descriptions of individual components and construction details. Each design also specifies the test standard(s) used and performance ratings achieved so code compliance can be determined. Windstorm rated products in the following categories include Classified products that have been investigated for use in the windstorm rated assemblies described above. These products, by themselves, have not been investigated for specific windstorm performance ratings, except as noted in the individual Classifications.

Windstorm Rated Exterior Swinging Doors ([ZHCW](#)) - This category covers exterior swinging doors intended for use as components in swinging door type windstorm-rated assemblies (not window assemblies, skylights, louvers or shutters). The performance of these doors is based upon test methods in ANSI/SDI-BHMA A250.13, Testing and Rating of Severe Windstorm Resistant Components for Swinging Door Assemblies.

Information needed to determine the acceptability of a particular installation is noted in individual Classifications. Doors prepared at the factory for glazing materials include the glazing members (framing) but are not required to include glazing itself. Glazing materials may be provided by other than the door manufacturer, and are installed at the same time as the door.

These products are intended to be installed in accordance with the installation instructions/manuals provided by the door manufacturer. The installation instructions include the type(s) and size(s) of glazing materials permitted, and the accessories or hardware permitted that are not Classified separately.

Windstorm Rated Door Frames ([ZHDL](#)) - This category covers door frames intended for use in swinging door windstorm-rated assemblies. The performance of door frames for exterior swinging doors as a component of an assembly is based upon test methods in ANSI/SDI-BHMA A250.13. The manufacturer and model number of the frame, wall type, opening size, maximum design pressure and maximum impact energy resistance are identified in each Classification.

These door frames are intended to be installed in accordance with ANSI/SDI A250.11, Recommended Erection Instructions for Steel Frames, unless indicated otherwise in the individual manufacturers' Classifications.

Products for use in Windstorm Rated Assemblies ([ZHLL](#)) - This category covers products intended for use in windstorm-rated assemblies ([ZHLA](#)).

These products are tested as part of a specific assembly or assemblies and include doors, frames, hardware, louvers, light kits and glazing.

Other categories for Windstorm Rated Products — Product categories have been established to cover other products that have been investigated for use in windstorm rated assemblies, including:

- Glass Light Frames for Windstorm Rated Doors ([ZHDO](#))
- Hinges ([ZHDX](#))
- Latching Hardware ([ZHEM](#))
- Accessories for Windstorm Rated Swinging Doors ([ZHCK](#)).

Installation considerations - To determine if a particular windstorm rated assembly is suitable for use in a specific application, first identify all test standards or protocols and performance ratings specified by the codes or regulations being enforced. Then, review the appropriate windstorm rated assembly certification to determine if it complies with all mandated test criteria. Finally, verify that the assembly is constructed and installed in accordance with the details included in the individual certification, manufacturer's instructions, and any applicable installation standards. Care should be taken to ensure that products used in the assembly include appropriate UL Classification Markings, as described in the design.

5. DOOR AND WINDOW SELECTION AND INSTALLATION

In order to properly select door and window assemblies one needs to know and understand the building design criteria, applicable code requirements, and select the appropriate UL certified products. The following steps provide a systematic approach that can be followed to provide a safe, code compliant installation. This process can also be used by code authorities during the building approval process.

This process applies primarily to doors, but some of the concepts are also applicable to windows, specifically those intended to restrict the movement of fire and smoke in a building.

1. Determine the size and location of doors – A number of factors dictate the number, size and location of doors to be provided in a building. These may be driven by code requirements or by the needs of the occupants and tenants.

Locations – Building and life safety codes require doors to be provided in certain specified locations to protect the door openings. This includes protecting door openings (1) in fire and smoke rated walls and partitions, (2) between dwelling units and attached garages, and (3) in various portions of the means of egress system. Besides the locations specified by code requirements, doors are also provided in locations to meet the needs of the building occupants. This includes doors that provide privacy, limit access, isolate equipment, provide security, etc.

Door sizes - Door sizes are sometimes dictated by code requirements. This is particularly true if the door is located in the means of egress system, or is covered by accessibility requirements. In addition minimum door sizes are sometimes specified for selected occupancies, e.g. a one and two family home requires a minimum 32 inch wide door.

The code and building design documents should be consulted to determine the size and locations of various doors within the building.

2. Confirm if doors and windows are required to limit the passage of fire or smoke – The fire safety system embodied in building code requirements is based on the use of walls and partitions designed to contain fires and the resulting smoke and products of combustion in certain areas within the building. This concept is often referred to as compartmentation (e.g. containing fires within various compartments). Codes require doors and windows that protect openings in these walls and partitions to comply with specific UL standards, and to have certain ratings in order to limit the spread of fire and/or smoke.

To determine the standards and ratings these doors must meet, one first needs to determine if the walls in which they installed are covered by code requirements.

Fire Walls, Fire Barriers and Fire Partitions

These are all vertical assemblies designed to restrict the spread of fire in which continuity is maintained. All of these assemblies are required to have a fire-resistance rating. However the hourly rating, construction, extent of continuity and support for these structures varies.

Door and window openings in these assemblies are required to be protected in accordance with the opening protective requirements in the code, and they may be limited to a maximum individual size and aggregate width.

Fire door assemblies typically have an hourly fire-resistance rating somewhat less than the corresponding hourly rating of the vertical (wall) assembly. They should be certified in accordance with UL 10A, 10B, 10C, 14B and/or 14C, as applicable, and installed in accordance with NFPA 80.

Fire Window assemblies typically have an hourly fire-resistance rating somewhat less than the corresponding hourly rating of the vertical (wall) assembly. They should be certified in accordance with UL 9, and installed in accordance with NFPA 80.

Smoke Barriers and Smoke Partitions

Smoke barriers are continuous membranes, either vertical or horizontal, such as a wall, floor or ceiling assembly, that are designed to restrict the movement of smoke through a building. In addition to limiting the spread of smoke, smoke barriers have a fire-resistance rating as specified in the installation code. Smoke partitions are continuous vertical membranes, such as a wall, that are also designed to restrict the movement of smoke through a building.

Door and window assemblies in smoke barriers are required to be protected against fire and smoke leakage in accordance with requirements included in the opening protective portion of the code. Door assemblies in smoke partitions are required to be protected with by specific construction and air leakage requirements.

To determine the appropriate standards and ratings for door in these assemblies, refer to the specific code requirements covering the wall assemblies. This will include a leakage rating for doors and windows used in smoke barriers and partitions, in conjunction with hourly fire-resistance ratings for doors and windows in smoke barriers.

3. Identify the wall construction – Once the size, location, standards and ratings required for the door and window assemblies are established, the next step is identify the construction of the walls into which they will be mounted. This is important to know because it affects the anchoring of the door frames, transoms and side lights.

For example fire door and window frames used in walls with wood or steel studs and gypsum wall board construction are anchored differently than frames installed in concrete or block walls. The proper frame should be selected for each of these applications. The manufacturer's installation instructions and NFPA 80 should be referred to for these details.

4. Determine the type of door required – There are a wide variety of fire door types that are listed with specific constructions features and for use in specific applications. These include rolling steel, sliding type, swinging type, and elevator type doors. Refer to Appendix A for a complete list of these door types.

5. Means of egress considerations – Doors serving a means of egress system for a building are required to comply with specific requirements that will help facilitate the egress of occupants from the building in an emergency. It is important to identify the doors in the building that are subject to specific egress related requirements, as covered in the Means of Egress chapter of the code.

Egress requirements include minimum door widths, projections into the doorways, and door swing requirements. It also includes specific requirements related to the use of revolving, sliding and power operated doors.

Egress requirements also require these doors to be readily operable from the egress side without the use of a key or special knowledge or effort, and to include panic hardware that is listed in accordance with UL 305. There are also requirements in place for special locking arrangements that allow for egress while also providing a suitable level of security for the premises.

6. Glazing – Glazing used in fire doors, transoms, sidelights and fire windows is regulated in the opening protective portion of the code, and may be limited in aggregate and individual sizes and dimensions. Glazing is required to be listed in accordance with UL 9 and/or UL 263 requirements, and may consist of fire-protection or fire-resistance rated glazing. Glazed areas subject to human impact loads, such as in a door or side transom, are also required to meet safety glazing requirements. Wired glass is not permitted in those areas.

7. Select appropriate hardware – In order to operate properly, door hardware needs to be outfitted on the door assemblies. This hardware may include hinges, latches, locks, closers, and panic exit hardware. Most of these products are Listed in accordance with UL standards.

8. Putting it all together – In order to provide the desired door installation that complies with applicable code requirements it is important to identify the wall construction, determine the type of door required, evaluate means of egress considerations, understand the requirements applicable to glazing, and select the appropriate hardware. Likewise for a fire window installation it is important to identify the wall construction, the type of glazing required and the appropriate frame for the glazing and wall construction.

Care should be taken to verify that the doors, frames, glazing and hardware are installed in accordance with the manufacturer’s installation instructions, and in accordance with NFPA 80 requirements.

6. DIAGRAMS OF COMPLETE ASSEMBLIES

The following diagrams identify the components that make up complete assemblies, along with links to the guide information for the various product categories. Refer to Appendix for a complete list of related product categories.

ROLLING STEEL FIRE DOOR ILLUSTRATION

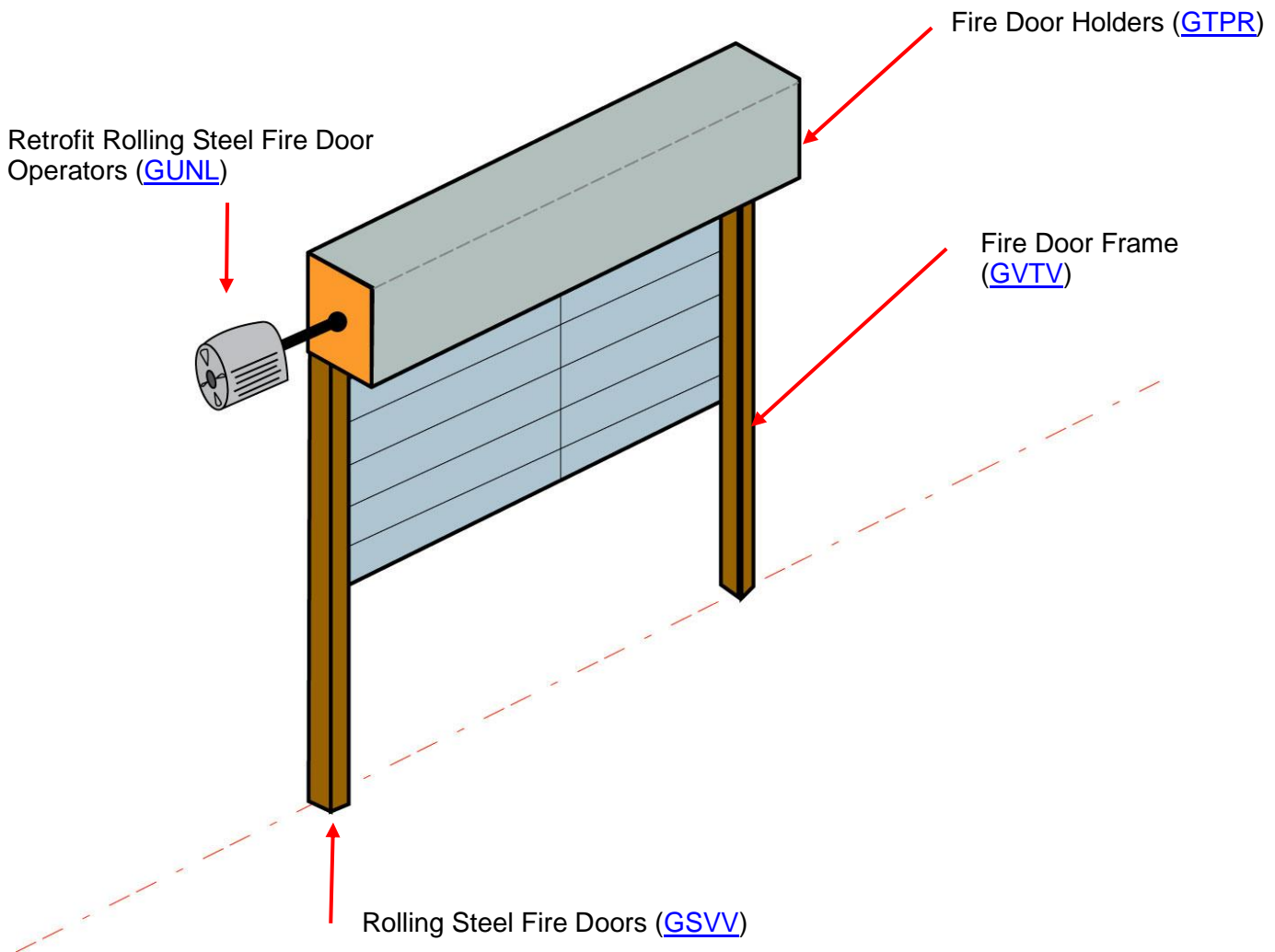

SWINGING-TYPE FIRE DOOR ILLUSTRATION

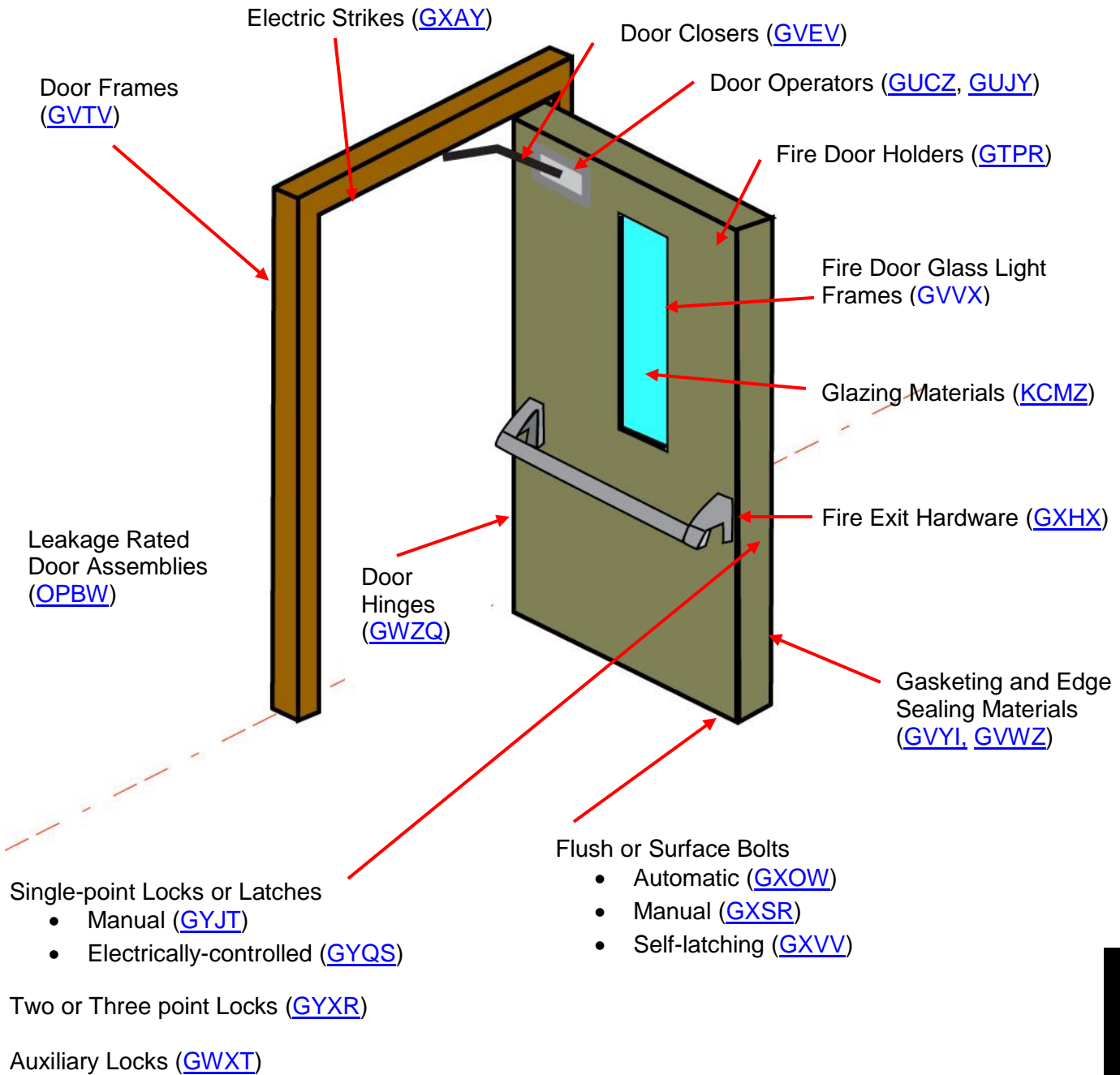

Swinging-type Fire Door
([GSZN](#) for UL 10C, [GSYX](#) for UL 10B)

DOUBLE FIRE DOOR ILLUSTRATION

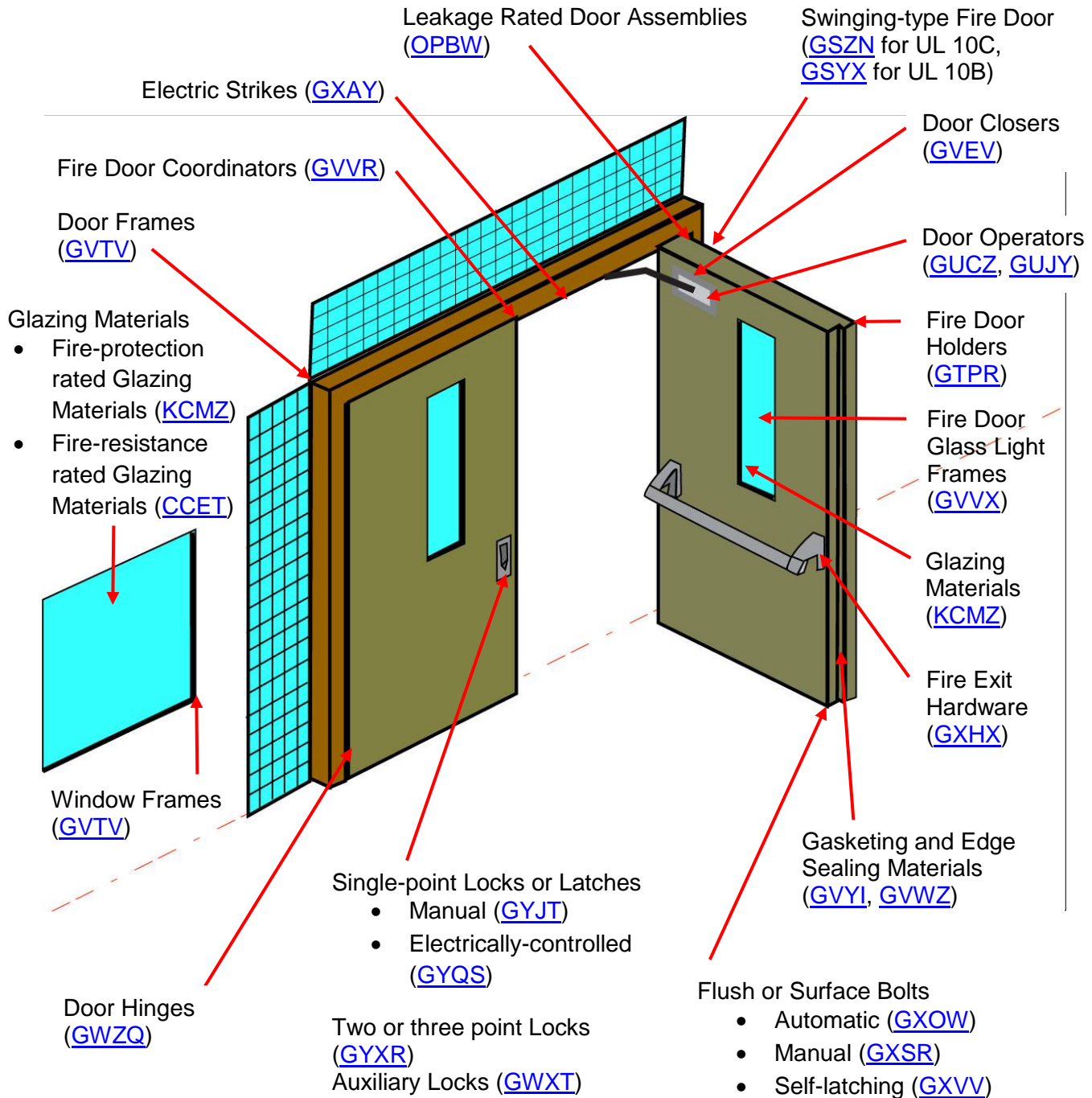

APPENDIX A - CODES AND STANDARDS

Model codes - Doors, windows and related hardware have been investigated for installation in accordance with the following model codes, among others:

- The International Building Code
- The NFPA 101 Life Safety Code
- The NFPA 5000 Building Construction and Safety Code

Among other things these codes specify the locations in which these products are to be installed, the ratings required for each installation, the standards with which the products must comply, the related installation standards, and other details.

Product safety standards - In many cases installation codes require products to comply with UL Standards for Safety, such as the Standard for Tin-Clad Fire Doors, UL 10A, Fire Tests of Door Assemblies, UL 10B or the Standard for Positive Pressure Fire Tests of Door Assemblies, UL 10C. These are product safety standards that include a comprehensive set of construction and/or performance requirements that products must comply with in order to be certified (Listed) by a product certification organization such as UL.

Manufacturers use UL product safety standards to design their products so they comply with the applicable requirements. Product testing and certification organizations such as UL use these standards to evaluate the products and determine their compliance with the product standards.

When UL has determined that a product complies with all applicable product safety standards, the manufacturer is authorized to apply a UL Certification Mark (Listing or Classification) to production of the product. The standard(s) used to investigate UL Certified products are identified in the product category guide information found in the UL Online Certification Directory www.ul.com/database. The product safety standard may also be marked on the product or indicated in the manufacturer's installation instructions.

When an installation code or standard requires a product, system or assembly to comply with a UL standard, designers, contractors and code authorities are encouraged to look at the certification mark on the product and the corresponding guide information to identify the product safety standard used during the investigation. It is not generally necessary, or useful, for designers, contractors and code authorities to obtain a copy of the UL product safety standard.

Installation standards – As compared to installation codes, which generally describe where doors, windows and related hardware are to be installed, installation standards provide more detailed information on how the products are intended to be installed and maintained. Model codes often require doors, windows and related hardware to be installed in accordance with installation standards, such as NFPA 80 and NFPA 105. A brief summary of these standards is noted below.

NFPA 80

NFPA 80 is the Standard for Fire Doors and Other Opening Protectives. It regulates the installation and maintenance of assemblies and devices used to protect openings in walls, floors, and ceilings against the spread of fire and smoke within, into, or out of buildings. The standard addresses assemblies that have been subjected to standardized fire tests, including UL fire tests.

NFPA 80 includes general requirements that cover the following areas.

- General limitations related to preparation and installation
- Listed and labeled products requirements
- Classifications and types of doors
- Glazing material in fire doors
- Fire-resistance rated glazing in doors and windows
- Classification of hardware for fire doors
- Placement of detectors, including fusible links
- Supporting construction for the assemblies
- Testing to be conducted upon completion of installation

NFPA 80 includes requirements covering the care and maintenance of fire doors and other opening protectives. This covers topics such as operability, repairs, field modifications, annual inspection records, visual inspections, functional testing and various other observations on adjustments, and maintenance of closing mechanisms based on the type of door.

If field modifications to a fire door or a fire door assembly are desired that are not specifically addressed in NFPA 80 or the manufacturer's installation instructions, NFPA 80 requires the laboratory (e.g. UL), that listed the product or component being modified, to be contacted and provided with a description of the modifications. An example of such a modification would be adding cladding to the door or cutting openings in it. If the laboratory finds that the modifications will not compromise the integrity and fire resistance capabilities of the assembly, the code authority is then permitted to approve the modification.

NFPA 105

NFPA 105 is the Standard for Smoke Door Assemblies and Other Opening Protectives. It includes requirements for smoke door assemblies to restrict the movement of smoke through door assemblies in order to maintain a tenable environment. It does this by regulating the installation, maintenance, and testing of smoke door assemblies. It is applicable to smoke door assemblies that restrict the passage of smoke at temperatures up to 400°F (204°C).

NFPA 105 includes requirements for the testing, installation and maintenance of smoke door assemblies. This covers topics such as operability, replacement, repairs, annual inspections, prevention of door blockage and maintenance of closure mechanism.

Smoke door assemblies that are intended for use as fire door assemblies are also required to comply with NFPA 80. Doors without fire protection ratings are permitted to be used as smoke doors in door openings not required to be protected by fire doors.

Other Standards

In addition to the installation standards noted above, the following standard may be useful.

Fire Door and Window Frames – The Steel Door Institute Recommended Erection Instructions for Steel Frames, SDI A250.11, is an ANSI approved standard. It includes recommended methods for the installation of steel frames for swinging doors in a variety of wall conditions which are commonly used in commercial buildings. The installation of transom/sidelight (or panel) type frames and single or multiple borrowed lights are not covered in this standard.

APPENDIX B - DOOR, WINDOW AND RELATED HARDWARE CATEGORIES

UL certifies the door, window and related hardware under the following product categories. Click on Category Code links to view UL Guide Information for the product category. The Guide Information also has links to manufacturers whose products are certified under the category. To view all UL certifications (e.g. Listings and Classifications) see the UL Online Certifications Directory at www.ul.com/database.

Category Code	Category Name	Standard Used
GSNV	Fire Doors	
GSNN	Fire Door Assemblies and Window Assemblies	UL 10B, UL 10C, or UL 9
GSOT	Access-type Fire Doors	UL 10B or UL 263
GSOX	Bullet-resisting-type Fire Doors	UL 10B and UL 752
GSPR	Chute-type Fire Doors	UL 10B
GSQX	Curtain-type Fire Doors	UL 10B and UL 555
GSRV	Dumbwaiter-type Fire Doors	UL 10B
GSZC	Finishers of Fire Doors	UL 10B or UL 10C, UL 1784
CCJV	Floor Access Doors	UL 263
GSST	Freight-elevator-type Fire Doors	UL 10B
GSSZ	Freight-elevator-type Fire Door Retrofit Parts	UL 10B
GSUX	Passenger-elevator-type Fire Doors	UL 10B
GSVV	Rolling Steel Fire Doors	UL 10B
GSWT	Service-counter-type Fire Doors	UL 10B
GSXV	Sliding-type Fire Doors	UL 10B and UL 10A
GSXZ	Special-purpose Fire Doors	UL 10B, UL 1784
GSYX	Swinging-type Fire Doors	UL 10B and UL 10A, UL 1784
GSZG	Swinging-type Fire Door Retrofit Parts	UL 10B
GSZN	Swinging-type Fire Doors, Positive-pressure Tested	UL 10C, UL 1784
GSZV	Tin-clad-type Fire Doors	UL 10A and UL 10B
GSSN	Fire-protective Curtains	UL Subject 10D, UL 1784
GVZS	Fire Door Louvers	UL 10B or UL 10C
OPBW	Leakage-rated Door Assemblies	UL 1784
	Fire Windows	
CCET	Fire-resistance-rated Glazing Materials	UL 263
KCMZ	Fire-protection-rated Glazing Materials	UL9, UL 10B, and/or UL 10C
	Fire Door and Window Frames	
GVTV	Fire Door and Window Frames	UL 10B, UL 10C, UL 9, or UL Subject 63
GVUP	Finishers of Fire Door Frames and Fire Window Frames	UL 10B, UL 10C, UL 9 or UL Subject 63

GWGR	Fire Door and Window Hardware	
GWVW	Accessories for Single-point Locks and Latches and Fire-exit Hardware	UL 10C
GWXT	Auxiliary Locks	UL 10C or UL 10B
GWZQ	Door Hinges	UL 10C, ASTM F 1450
GXAY	Electric Strikes	UL 10C
GXHX	Fire-exit Hardware	UL 305, UL 10B, UL 10C
GXLK	Fire Exit Hardware, High Security	UL 305, UL 10C, UL 768
GXOW	Flush and Surface Bolts, Automatic Type	UL 10B or UL 10C
GXSR	Flush and Surface Bolts, Manual Type	UL 10B or UL 10C
GXVV	Flush and Surface Bolts, Self-latching Type	UL 10B or UL 10C
GYJT	Single-point Locks and Latches	UL 10B or UL 10C
GYQS	Electrically-controlled Single-point Locks and Latches	UL 10B or UL 10C
GYXR	Two- and Three-point Locks and Latches	UL 10B
GZKZ	Elevator Fire Door Hardware, Passenger	UL 10B
GZYG	Fire Door Hardware	UL 14B, UL 14C
HAAU	Fire Door Viewers	UL 10B or UL 10C
GVUW	Fire Door Accessories	
GVVR	Fire Door Coordinators	UL 10B or UL 10C, and UL Subject 14
GVUX	Miscellaneous Fire Door Accessories	UL 10B
GVUY	Miscellaneous Fire Door Accessories, Positive-pressure Tested	UL 10C
GVUZ	Cladding Materials for Fire Doors and Frames	UL 10B or UL 10C
GVVX	Fire Door Glass Light Frames	UL 10B or UL 10C
GVWZ	Gasketing Materials for Fire Doors	UL 10B
GVYI	Gasketing and Edge-sealing Materials for Fire Doors, Positive-pressure Tested	UL 10C
GTBT	Fire Door Closers, Holders and Operators	
FUOR	Door Closers	BHMA A156.4
GVEV	Swinging Fire Door Closers	UL 228
GUQX	Sliding Fire Door Closers	UL 228
GTPR	Fire Door Holders	UL 228
GTIS	Combination Fire Door Closers and Holders	UL 228
GUCZ	Fire Door Operators	UL 228 and UL 325
GUJY	Fire Door Operators with Automatic Closers	UL 228 and UL 325
GUNL	Retrofit Rolling Steel Fire Door Operators	UL 10B and UL 325
FCQU	Door Operators for use in Hazardous Locations	UL 325
FDGF	Door Holders for use in Hazardous Locations	UL 228

Means of Egress Related Certifications		
FUDQ		
FULA	Controlled Exit Panic Devices	
FUOR	Door Closers	
FUXV	Exit Doors	
FUQV	Exit Locks	
FVSR	Panic Hardware	
FWAX	Special Locking Arrangements	
Windstorm Rated Assemblies		
ZHCH	Windstorm-rated Swinging Door Components	
ZHCK	Accessories for Windstorm-rated Swinging Doors	ANSI/SDI-BHMA A250.13
ZHCW	Swinging Doors, Exterior	ANSI/SDI-BHMA A250.13
ZHDL	Door Frames	ANSI/SDI-BHMA A250.13
ZHDO	Glass Light Frames for Windstorm-rated Doors	ANSI/SDI-BHMA A250.13
ZHDX	Hinges	ANSI/SDI-BHMA A250.13
ZHEM	Latching Hardware	ANSI/SDI-BHMA A250.13
ZHLA	Windstorm-rated Assemblies	
ZHLL	Products for Use in Windstorm-rated Assemblies	ASTM E 330, ASTM E 1886, ASTM E 1996, AAMA/WDMA/CSA 101/I.S.2/A440, and/or ICC 500

APPENDIX C: DOOR AND WINDOW CODES AND STANDARDS

Doors and windows are intended to be installed in accordance with model codes and installation standards. These codes require these products to be listed and labeled in accordance with applicable product standards.

UL standards are typically identified as Standards for Safety and contain the construction, performance and marking criteria used by UL to investigate a product. Limitations applicable to the products covered by the standard are delineated in the Scope section of the standard. UL standards are intended to:

- Identify requirements for evaluation of products and provide consistency in the application of these requirements.
- Provide guidance for development of products by manufacturers.
- Provide requirements compatible with nationally recognized installation codes.

An UL Outline of Investigation is a document that contains the construction, performance, and marking criteria used by UL to investigate a product when the product is not covered by the scope of an existing UL Standard for Safety. Outlines are not consensus documents and do not require review by an UL Standards Technical Panel (STP) or other external group. For more information, go to www.ul.com/standards.

ASTM E330	Standard Test Method for Structural Performance of Exterior Windows, Doors, Skylights and Curtain Walls by Uniform Static Air Pressure Difference
ASTM E1886	Standard Test Method for Performance of Exterior Windows, Curtain Walls, Doors, and Impact Protective Systems Impacted by Missile(s) and Exposed to Cyclic Pressure Differentials
ASTM E1996	Standard Specification for Performance of Exterior Windows, Curtain Walls, Doors and Impact Protective Systems Impacted by Windborne Debris in Hurricanes
ASTM F1450	Standard Test Methods for Hollow Metal Swinging Door Assemblies for Detention Facilities
ANSI/BHMA A156.3	Exit Devices
ANSI/BHMA A156.4	Door Controls - Closers
FEMA Publication 320	Taking Shelter From the Storm: Building a Safe Room for Your Home or Small Business
FEMA Publication 361	Design and Construction Guidance for Community Safe Rooms
IBC	International Building Code
ICC 500	ICC/NSSA Standard for the Design and Construction of Storm Shelters
IFC	International Fire Code
NFPA 1 (UFC)	Uniform Fire Code
NFPA 80	Standard for Fire Doors and Other Opening Protectives
NFPA 101	Life Safety Code

NFPA 105	Standard for Smoke Door Assemblies and Other Opening Protectives
NFPA 5000	Building Construction and Safety Code
ANSI/SDI-BHMA A250.13	Testing and Rating of Severe Windstorm Resistant Components for Swinging Door Assemblies
TAS 201 (State of Florida Building Code)	Impact Test Procedures
TAS 202 (State of Florida Building Code)	Criteria for Testing Impact and Non-Impact Resistant Building Envelope Components Using Uniform Static Air Pressure
TAS 203 (State of Florida Building Code)	Criteria for Testing Products Subject to Cyclic Wind Pressure Loading
UL 9	Fire Tests of Window Assemblies
UL 10A	Tin-Clad Fire Doors
UL 10B	Fire Tests of Door Assemblies
UL 10C	Positive Pressure Fire Tests of Door Assemblies
UL Subject 10D	Outline of Investigation for Test Methods for Fire Protective Curtains
UL 14B	Sliding Hardware for Standard Horizontally
UL 14C	Swinging Hardware for Standard Tin-Clad Fire Doors
UL Subject 63	Outline of Investigation for Fire Door Frames
UL 228	Door Closers-Holders, With or Without Integral Smoke Detectors
UL 263	Fire Tests of Building Construction and Materials
UL 294	Access Control System Units
UL 305	Panic Hardware
UL 325	Door, Drapery, Gate, Louver, and Window Operators and Systems
UL 555	Fire Dampers
UL 752	Bullet-Resisting Equipment
UL 768	Combination Locks
UL Subject 1336	Outline of Investigation for Exit Doors
UL 1784	Air Leakage Tests of Door Assemblies
AAMA/WDMA/CSA 101/I.S.2/A440	Standard/Specification for Windows, Doors, and Unit Skylights

INDEX

A

Artificial bottom seals, 18

C

Category A Doors, 13
Category B Doors, 13
Category C Frames, 13
Category D Door/Frame Assemblies, 13
Category F Light Kits, 13
Category G Edge Sealing Systems, 13, 20
Category H Smoke and Draft Control
 Gasketing, 13, 20
Category J Gaskets, 13, 20
Codes and standards, 30, 35
Controlled Exit Panic Devices, 21

D

Door selection and installation, 24
Double fire door illustration, 29

E

Edge seal materials, 19
Edge sealing systems, 13
Exit Doors, 21
Exit Locks, 21

F

Field evaluations, 6
Fire and smoke protection, 2
Fire barriers, 24
Fire door frames. *See* Frames
Fire doors, 11
 Fire-protection ratings, 11
 Glazing materials, 12
 Markings, 14
 Oversized doors, 12
 Positive pressure fire doors, 13
 Temperature rise ratings, 11
Fire exit hardware, 19
Fire partitions, 24
Fire walls, 24
Fire window frames. *See* Frames
Fire-protection-rated glazing, 11
Fire-resistance-rated glazing, 10
Frames, 14
 20-minute rated, 16
 Elevator, 15
 Fire door, 14

Fire window, 14
Hourly ratings, 15
Installation instructions, 15
Listing Mark considerations, 14
Oversized, 16
Positive pressure, 17
Special use, 15
Window, 17

G

Gasketing, 19
Gasketing, smoke and draft control, 13

H

Hardware, door and window, 19

I

Installation standards, 30

L

Leakage rated door assemblies, 18
Light kits, 13
Listing versus Classification, 4

M

Means of egress, 2
 Code requirements, 20
 Considerations, 26
 Controlled exit panic devices, 21
 Exit doors, 21
 Exit locks, 21
 Panic hardware, 21
 Related door certifications, 20
 Special Locking Arrangements, 22

Model codes, 30

Mullions, 16

N

NFPA 105, 31
NFPA 80, 30

O

Opening protectives, 10
Oversized fire window frames, 18
Oversized frames, 16

P

Panic Hardware, 21

Positive pressure fire doors, 13
Positive pressure frames. *See* Frames
Product category information, 32
Product safety standards, 30

R

Rolling steel fire door illustration, 27

S

S rated door assemblies, 18
SDI A250.11, 31
Smoke barriers, 25
Smoke partitions, 25
Special Locking Arrangements, 22
Standards, 30
Swinging type fire door illustration, 28

T

Transom panels, 16

U

UL 1784, 18
UL 263, 10

UL 294, 22
UL Classification Mark, 6
UL Listing Mark, 6
UL Mark considerations, 5

W

Wall construction, 25
Window frames, 17
Window selection and installation, 24
Windows
 Oversized, 18
Windstorm rated assemblies, 2
Windstorm rated building products, 22
 Door frames, 23
 Doors, 23
 Glass light frames, 23
 Hinges, 23
 Installation considerations, 23
 Latching hardware, 23
 Swinging door accessories, 23
 Swinging door assemblies, 22
Windstorm Rated Swinging Door
 Components, 22