



LUMEN INSIGHTS™

May/June 2011

2 UL 8750 Fire Enclosure Requirements

3 Making Serious Light of Metals

4 The Blue Light Hazard

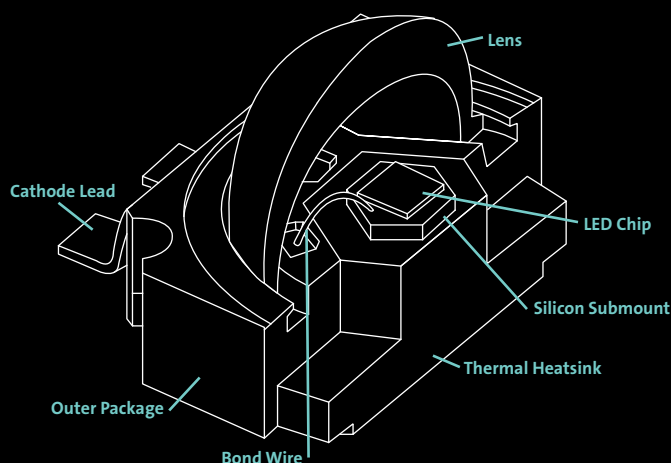

LED Package Recognition

By Bahram Barzideh/Principal Engineer SSL and Matthew Sallee/Global SSL Business Manager

UL is committed to advancing and innovating safety, providing certainty to more people, businesses and governments. As a technical leader in Solid State and LED Lighting technologies, UL has created a Component Recognition program for LED packages under the Category Control Number (CCN) OOQL2 (LED Packages – Component). A parallel category, OOQL8, provides certification for Canada.

Evaluation for LED Packages will be performed in accordance with UL 8750, 1st Edition- Standard for Light Emitting Diode (LED) Equipment For Use In

Lighting Products. For Canada, additional considerations are made for any applicable requirements of the Canadian Electrical Code and C22.2 No. 250.0-08.

Certifications under this program will carry value-added information regarding the characteristics of LED package as related to compliance with UL 8750. This information will provide LED package producers with a highly credible marketing channel, while concurrently providing LED equipment assemblers with an easily searchable on-line database of pre-certified components. UL is expanding our focus and

our footprint, enabling you to get your products and technologies to market with confidence.

With a track record of more than a 117-years in safety science, UL's breadth and expertise uniquely enable us to facilitate global trade by helping you identify key markets, navigate compliance mazes and offer information on regulatory and trade issues.

To learn more about this program please contact UL by visiting us on the web at www.ul.com/lighting.

A Letter from Alberto



From new recognition programs for LED Packages, to award-winning photometric testing equipment, UL continues to

innovate and expand what safety means for the rapidly changing lighting marketplace. Only UL has built a foundation of expertise that places us at the center of complex global safety dialogues.

Today in lighting, safety discussions are around more than risk of fire and shock. How can UL help foster new technology into the global marketplace, protecting people, products and places?

In this issue of Lumen Insights we focus on the LED Package: New Recognition Programs, New UL8750 requirements, New research on sustainability and photobiological hazards.

We look forward to seeing you at Lightfair, join our presentation on Photobiological safety during the show, and would welcome you to visit our booth 561.

Kind Regards,

*Alberto Uggetti
VP and GM Global Lighting*



UL 8750 Fire Enclosure Requirements

By Michael Shulman/Principal Engineer Lighting

A primary expectation for any product listed in accordance with a UL standard is that it will ‘do no harm.’ One example is if a fire were to start within the product — the product is expected to manage the situation in a manner that will not allow the incident to spread to the building or other products in the vicinity. To accomplish this, most UL standards have vigorous and demanding requirements for the product enclosure.

Polymer (plastic) materials used for an enclosure are typically required to comply with certain flammability ratings (such as 5V or V0, whose test methods are described in the UL 94 standard) that reflect the material’s ability to self-extinguish when faced with a fire incident. This ability is often related to the amount and type of flame retardant content in the formulation of the specific polymer.

Legacy luminaire technologies (incandescent, fluorescent, HID) use light sources made of metal and glass. Because these materials are non-flammable, the safety standards do not require them to be within a fire enclosure. LED technology, however, includes many small pieces of organic (potentially flammable) material in or near the light source, most notably the LED optics and the coating or insulating materials on the printed circuit board (on which the LEDs are mounted). So it is reasonable for the safety standard for LED equipment, UL 8750, to require this “fuel” to be adequately enclosed.

But there’s a conflict here — a higher levels of flame retardant can adversely impact optical clarity. LED equipment producers do not want to sacrifice optical performance, and they cannot sacrifice product safety.

UL will be presenting a potential solution at the UL 8750 Standard Technical Panel (STP) meeting this summer. Using hazard based safety engineering (HBSE) principles, UL will propose an alternative approach — rather than relying exclusively on an enclosure to contain a fire, certain exemptions to the fire enclosure requirements by instead reducing the risk of fire ignition by measurable limits on the available electrical or thermal energy can be applied to reduce the risk of fire ignition. If there is no ignition, there is no fire than needs to be contained. UL believes that this alternative fire management strategy will avoid the need to make any compromises between LED product safety and performance.

Making Serious Light of Metals

By Roger Franz/UL Environmental Scientist

The tungsten lamp that has been the mainstay of so many lighting applications for a hundred years is being phased out in favor of more energy efficient technologies. Two of the emerging candidates are compact fluorescent (CFL) and solid state lighting (SSL), the latter being based on light emitting diodes (LEDs). In this article we contrast the materials supply aspects of tungsten vs. LEDs.

Tungsten is a metal that is widely available from deposits in the US and Canada, although China is by far the dominant supplier and user. Tungsten has been named one of the Conflict Minerals due to trade practices and human rights the turmoil in the Republic of the Congo, along with tantalum, tin, and gold. While these social concerns have attracted attention, the US Geological Survey data¹ does not list any recent commerce based on the Congo's tungsten supply.

While providing significantly greater efficacy in terms of lumens per watt, LEDs are based on materials that are much more limited. A common type of semiconductor used to make LEDs is based on the periodic table group III and V elements, indium (In), gallium (Ga) and nitrogen (N), combined to make InGaN.

Neither indium or gallium exists in economically viable concentrations that can be used to produce them directly; rather, they are trace byproducts of mining and refining other primary metals like aluminum, zinc, copper or tin. And once they are fabricated into working diodes, there is no viable process today for recycling them back into further use. (On a positive note, nitrogen is very abundant, since it is some 78% of earth's atmosphere and as an element is not in short supply.)

Along with several other elements, indium and gallium have also been identified by materials scientists and physicists as Energy Critical Elements². Both indium and gallium may also be used in photovoltaic cells to capture solar energy, compounding the potential concern over their availability.

As a result, there is a need for research on alternative materials, ways to use less without sacrificing performance, and addressing the geopolitical aspects of supply assurance. By taking these actions, we can continue to move to the next level of renewable energy and lighting efficacy.

We'd openly welcome industry representatives to join the discussion through our Standards Technical Panel, while we write ULE106, Sustainability of Luminaires at <http://csds.ul.com>.

1 "Tungsten." 2008 Minerals Yearbook, U.S. Department of the Interior, U.S. Geological Survey.

2 "Energy critical Elements: Securing Materials for Emerging Technologies." American Physical Society (APS) Panel on Public Affairs and the Materials Research Society (MRS), Feb., 2011.



The Blue Light Hazard

By Winn Henderson/Subject Matter Expert, LED Optical Radiation

For visible lamp radiation, including the radiation emitted from LEDs, there is a specific concern about the hazards associated from the blue light wavelengths of the radiation. Blue light hazards are principally in the 400–500nm range with a peak of approximately 440nm. One of the main concerns is photochemical damage to the retina of the eye. Photochemical change occurs when light causes chemical reactions in the body’s tissue — in this case eye tissue. The damage to the retina could result in blind spots. The blue light hazard from lamp and LED radiation is specifically addressed in ANSI/IESNA RP 27 and IEC 62471.

The intent of Photobiological safety requirements are to protect the eye and skin from harmful optical radiation. Photobiological requirements are mandatory for many safety certification programs for Europe.

A proposal to incorporate photobiological safety requirements into UL 8750 has been

made to the Standards Technical Panel (STP). During the July STP meeting, this proposal will be discussed. This proposal would make photobiological testing mandatory for LEDs in North America.

UL can presently evaluate lighting products to both IEC 62471 and ANSI/IESNA RP 27 — the Photobiological Safety requirements

for lamps and lamp systems. UL currently has an IEC 62471 Certification Body Testing Laboratory (CBTL) in Research Triangle Park, NC, USA, and can issue CB Test Reports and Certificates to IEC 62471. UL is also able to perform Photobiological Safety testing in Europe and in Asia.

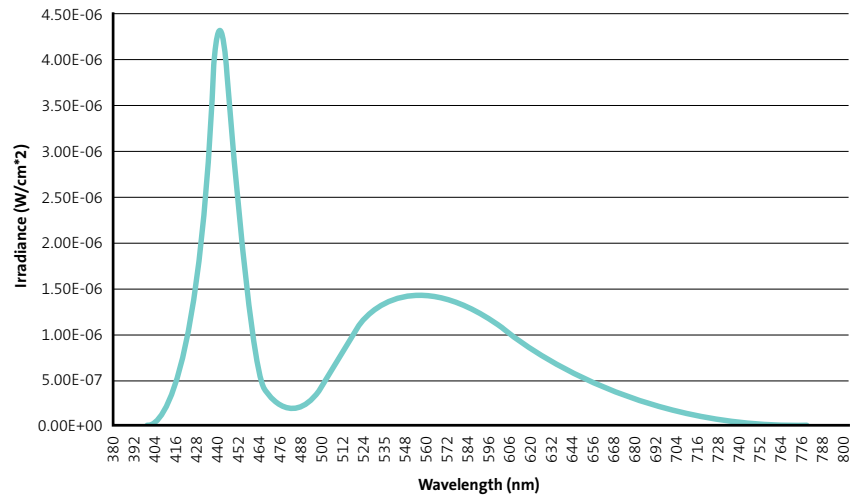

Come See Us

May 18, 2011 — 4:30PM
 Lightfair 2011 / Photobiological Safety Standards for LEDs – Are You Ready?
 UL Booth — 561



Training and Education Events

T: +1.888.503.5536
 E: ULUniversity@us.ul.com
 W: uluniversity.us

Designing for Compliance to UL 1598:
 Electric Luminaires
 June 7 – Northbrook, Ill.
 August 2 – Hartford, Conn.
 October 4 – Research Triangle Park, N.C.

LED Luminaires — Designing for Compliance to UL 8750 (In Accordance with UL 1598)
 June 8 – Northbrook, Ill.
 August 3 – Hartford, Conn.
 October 5 – Research Triangle Park, N.C.



Share Your Insights: Lumen.Insights@us.ul.com.
 Sign up at: www.ul.com/lumeninsights
 Managing Editor: Matthew.Sallee@matthew.sallee@us.ul.com



[UL Lumen Insights](#)



[UL Lumen Insights](#)



[@lumeninsights](#)